

IF IN DOUBT ASK
DO NOT SCALE

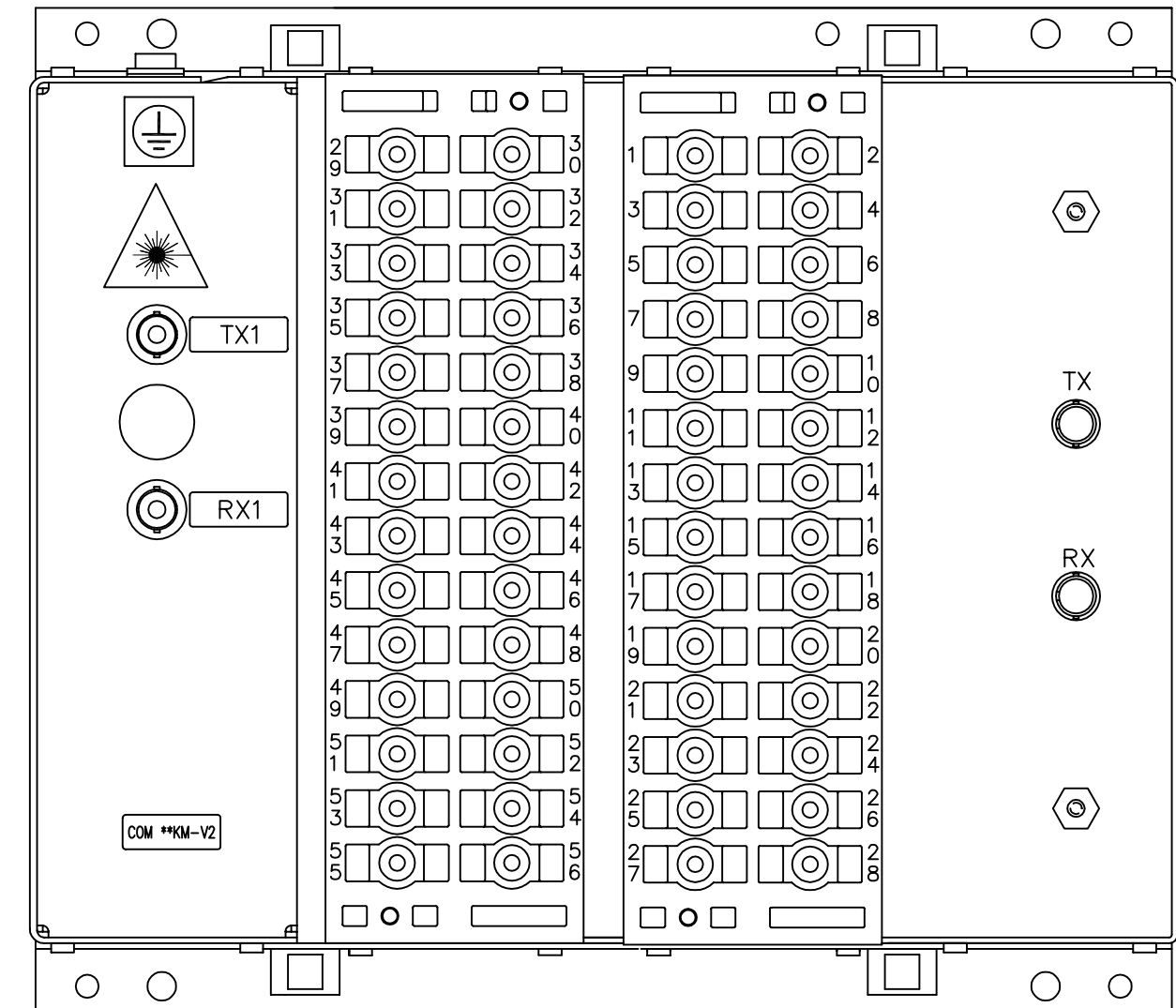
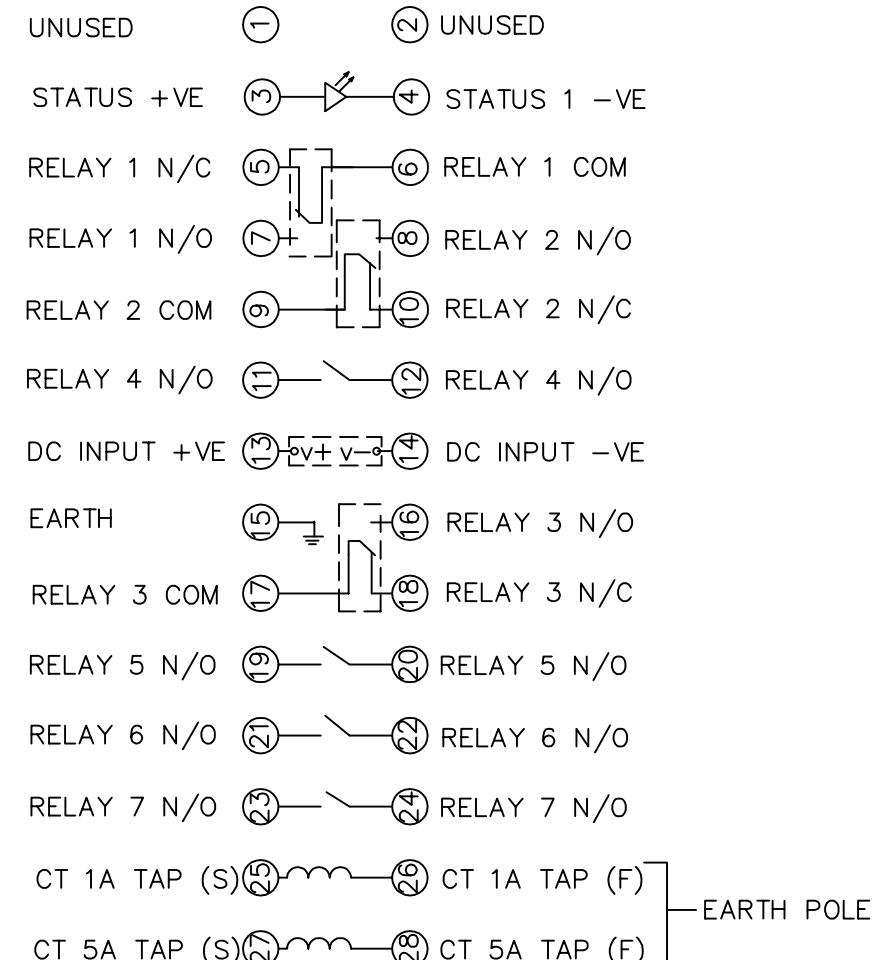
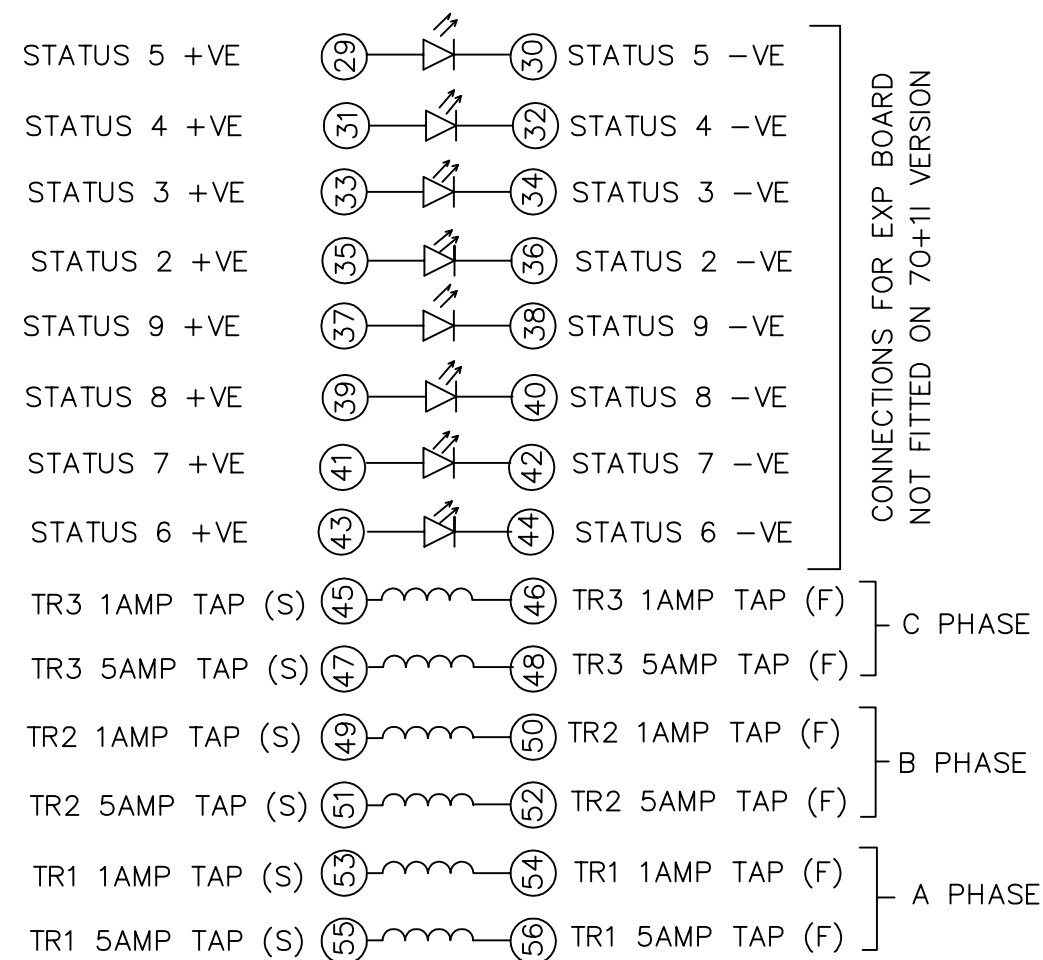

OUTER TERMINAL BLOCK ASSY: -
VIEW BLOCK FROM THE INSIDE FACE
ASSEMBLY INSTRUCTIONS: -

TYPICAL ASSEMBLY DRAWING 2995G10029
AT INDICATED POSITIONS FIT AS FOLLOWS,
S - FIT STANDARD CONTACT
2995B10051

HC - FIT 'HEAVY CURRENT' KIT
2995G10030

WHERE -o-o- IS SHOWN FIT
CT SHORTING KIT 2995G10031

POSITIONS SHOWN BLANK ARE UNUSED
ALL POSITIONS FIT SCREW 2106F12506

30	S	S	29
32	S	S	31
34	S	S	33
36	S	S	35
38	S	S	37
40	S	S	39
42	S	S	41
44	S	S	43
46	-o-o-		45
48	-o-o-		47
50	-o-o-		49
52	-o-o-		51
54	-o-o-		53
56	-o-o-		55

OUTER TERMINAL BLOCK ASSY: -
VIEW BLOCK FROM THE INSIDE FACE
ASSEMBLY INSTRUCTIONS: -

TYPICAL ASSEMBLY DRAWING 2995G10029
AT INDICATED POSITIONS FIT AS FOLLOWS,
S - FIT STANDARD CONTACT
2995B10051

HC - FIT 'HEAVY CURRENT' KIT
2995G10030

WHERE -o-o- IS SHOWN FIT
CT SHORTING KIT 2995G10031

POSITIONS SHOWN BLANK ARE UNUSED
ALL POSITIONS FIT SCREW 2106F12506

2	S	S	1
4	S	S	3
6	S	S	5
8	S	S	7
10	S	S	9
12	S	S	11
14	S	S	13
16	S	S	15
18	-o-o-		17
20	S	S	19
22	S	S	21
24	S	S	23
26	-o-o-		25
28	-o-o-		27

VIEW FROM NUMBERED SIDE OF BLOCK

ASSEMBLY INSTRUCTIONS: -

TYPICAL ASSEMBLY DRAWING 2995G10032
AT INDICATED POSITIONS FIT AS FOLLOWS,
T - FIT TRIP ISOLATION CONTACT
2995B10053

S - FIT STANDARD CONTACT
2995B10054

POSITIONS SHOWN BLANK ARE UNUSED

2	T	T	1
4	T	T	3
6	T	T	5
8	T	T	7
10	T	T	9
12	T	T	11
14	T	T	13
16	T	T	15
18	S	S	17
20	S	S	19
22	S	S	21
24	S	S	23
26	S	S	25
28	S	S	27

VIEW FROM NUMBERED SIDE OF BLOCK

ASSEMBLY INSTRUCTIONS: -

TYPICAL ASSEMBLY DRAWING 2995G10032
AT INDICATED POSITIONS FIT AS FOLLOWS,
T - FIT TRIP ISOLATION CONTACT
2995B10053

S - FIT STANDARD CONTACT
2995B10054

POSITIONS SHOWN BLANK ARE UNUSED

2	S	S	1
4	T	T	3
6	S	S	5
8	T	T	7
10	S	S	9
12	T	T	11
14	S	S	13
16	T	T	15
18	S	S	17
20	T	T	19
22	T	T	21
24	T	T	23
26	S	S	25
28	S	S	27

NOTES

- TERMINALS RECOMMENDED ARE PRE INSULATED & MUST BE CRIMPED USING APPROVED TOOLING.
AMP PIDG OR PLASTI GRIP FUNNEL ENTRY (RING TONGUE) FOR M4 FIXING STUD.

SUPPLIER	AMP	CABLE SIZE
AMP	342103	0.25-1.6 SQ MM
AMP	342143	1.0-2.6 SQ MM.

OR ANY OTHER MANUFACTURERS EQUIVALENT TERMINAL.

- FOR OUTLINE & DRILLING DRG SEE 2995X10008 (A4).

MATERIAL:

Dimensions in millimetres ; Surface texture in micrometres.
Machine where marked ✓
For explanation of dimensions, tolerances, notes etc. see B.S.308.
Limit on untoleranced unmachined dimensions ± _____
Limits on untoleranced machined dimensions to B.S.4500;
i.e. up to 6±0.1; over 30 to 120±0.3; over 315±0.8;
over 6 to 30±0.2; over 120 to 315±0.5;
General unmachined angular tolerance ± _____

Finish:

Treatment:

Title:
TERMINAL IDENTIFICATION & RELAY WIRING DIAGRAM
SOLKOR-N PROTECTION LED 0-16 & 0-49KM (E8 CASE)

VATECH REYROLLE
AUTOMATION, CONTROL & PROTECTION

Original Scale:
NTS

Dr. No.
2646W50004

Copyright © 2001 VATECH REYROLLE ACP Ltd. Hebburn

3 RDW	23/04/07	MN646/2870	SPK
2 RDW	28/01/04	MN646/2616	SPK
1	23/10/01	CHANGE	△
ISSUE	DATE	NOTED	

DRAWN	M LEASK	CHECKED	APPROVED	R.D.WATSON	DATE	23/07/02	IE	OPS	PCP	Purch.Spec.	TQ	EAC	CE	STD	A2
-------	---------	---------	----------	------------	------	----------	----	-----	-----	-------------	----	-----	----	-----	----